



2024.2 Software Release Highlights

- ❑ **HIL Global Time Synchronization**
 - C37.118 time synchronization
- ❑ **Train Real Time Data Protocol (TRDP)**
- ❑ **Six Phase PMSM with saturation effects**
- ❑ **Additional Features**
 - Up to four execution rates on 4th generation devices
 - Sinusoidal sources API function enhancement
 - Flexible Ethernet port selection
- ❑ **UX Improvements**
 - Component Bypassing
 - Add Schematic Area



HIL Global Time Synchronization

Synchronize your HIL device with the World Clock

- Global time synchronization
- Typically required when other equipment in the setup are also time synchronized
 - Particularly important for power systems applications

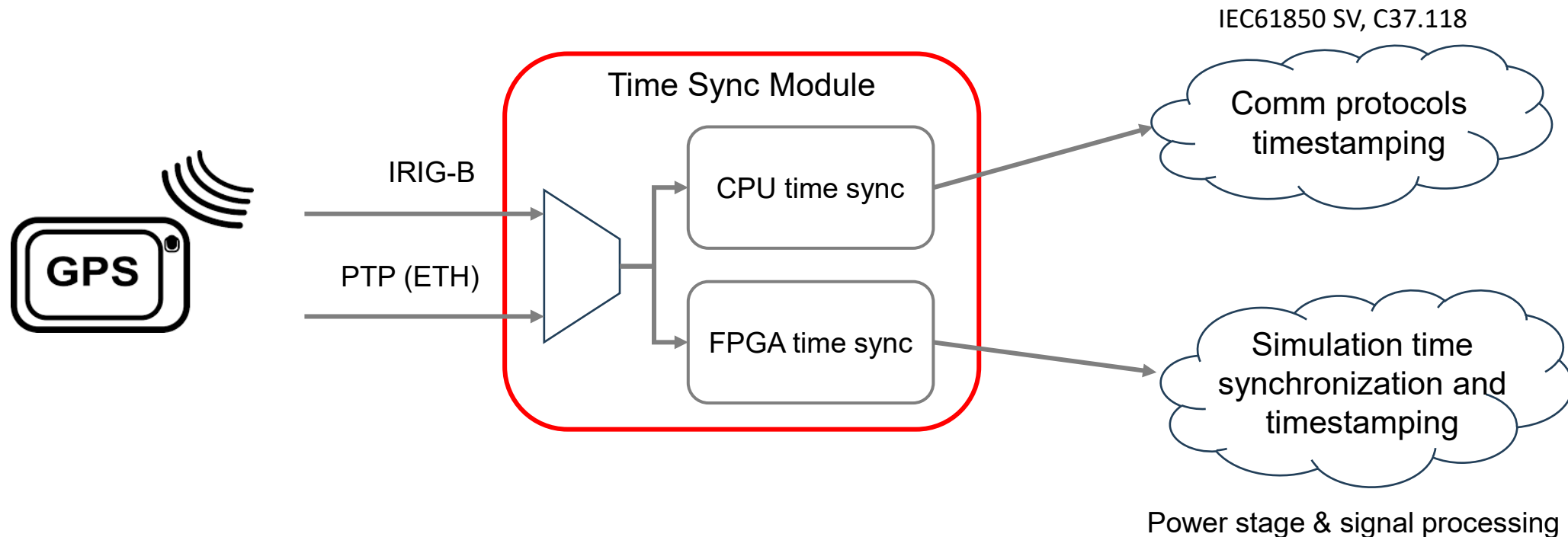

HIL Global Time Synchronization

Set your time synchronization source in one place

- Time synchronization component
 - Source selection and configuration
 - Synchronization status

- Capture function can now provide absolute trigger time
 - API support
 - GUI support

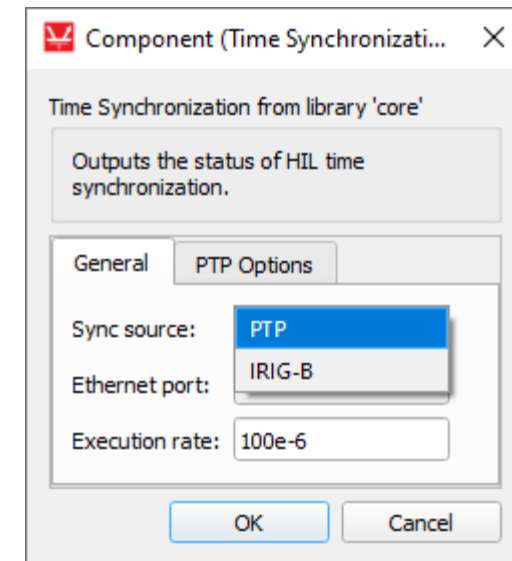
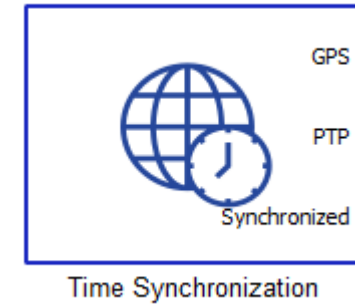

HIL Global Time Synchronization

Support for C37.118 time synchronization enabled

- Data transmission now aligned with system time
- Time between messages now optimized to prevent time drift

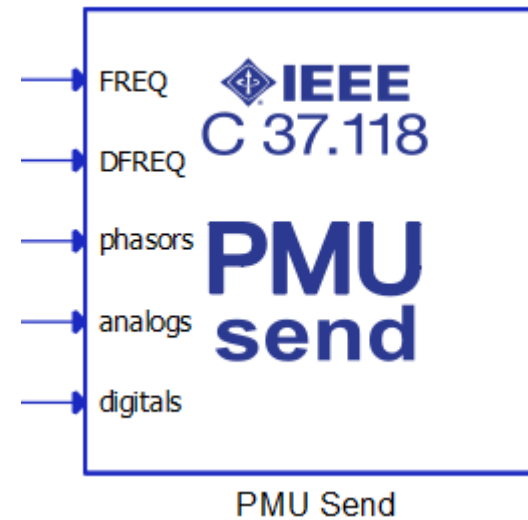

Train Real Time Data Protocol (TRDP)

Expanded communication protocol support for rail applications

- ❑ Communication protocol for IP-based communication in trains
- ❑ Based on IEC61375-2-3 Train Communication Network (TCN) communication profile
- ❑ Realized through dedicated Publisher and Subscriber components

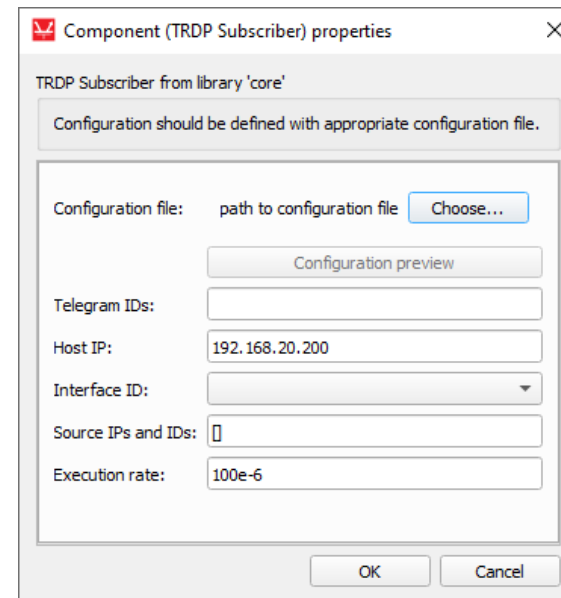
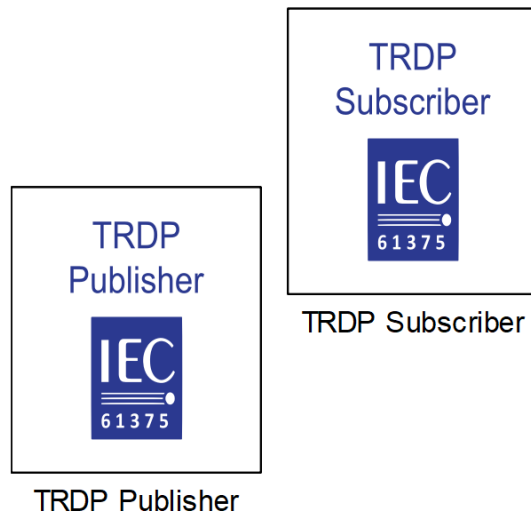

Six Phase PMSM model with saturation effects

Model 6-phase PMSMs with greater fidelity

- ❑ Six Phase PMSM nonlinear model developed, including magnetic saturation effects
- ❑ Machine self and mutual inductances, as well as the permanent magnet's fluxes, are functions of d- and q- components of the machine stator currents

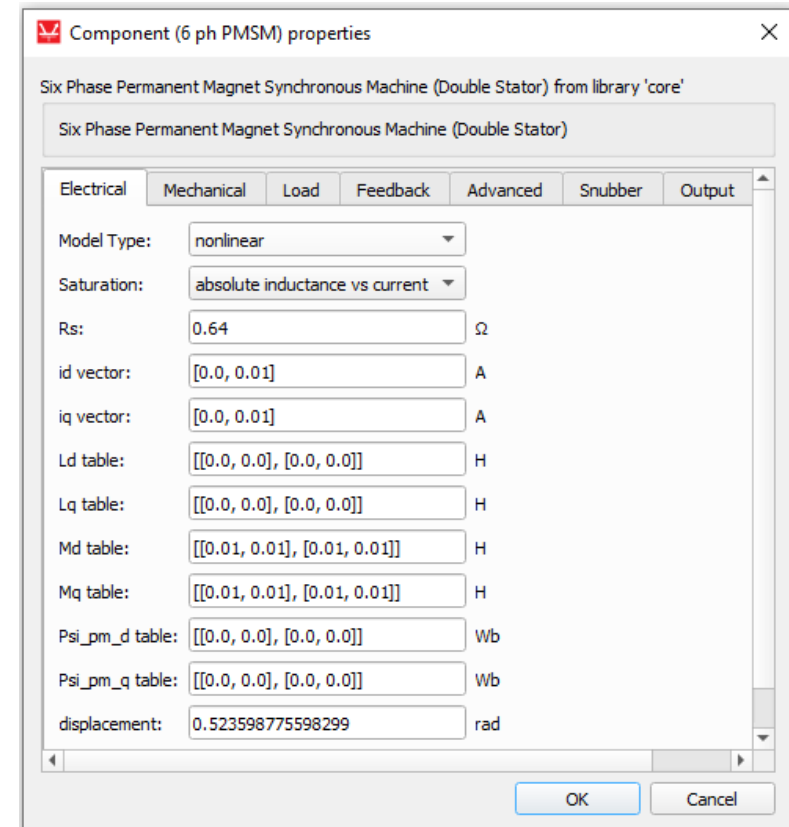
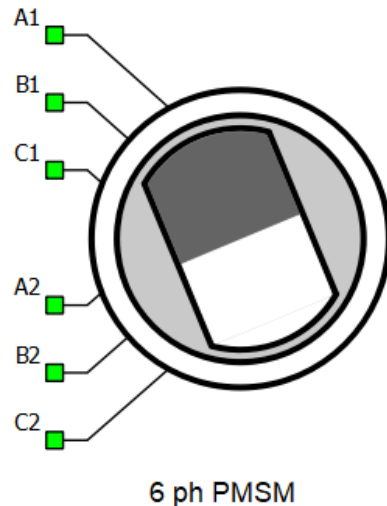

Additional Features

Increased maximum number of execution rates on 4th generation devices

- ❑ Number of Execution rates in the model now increased from 2 to 4 on HIL404 and HIL606

User CPUs

- ❑ Signal processing-domain modeling now more flexible

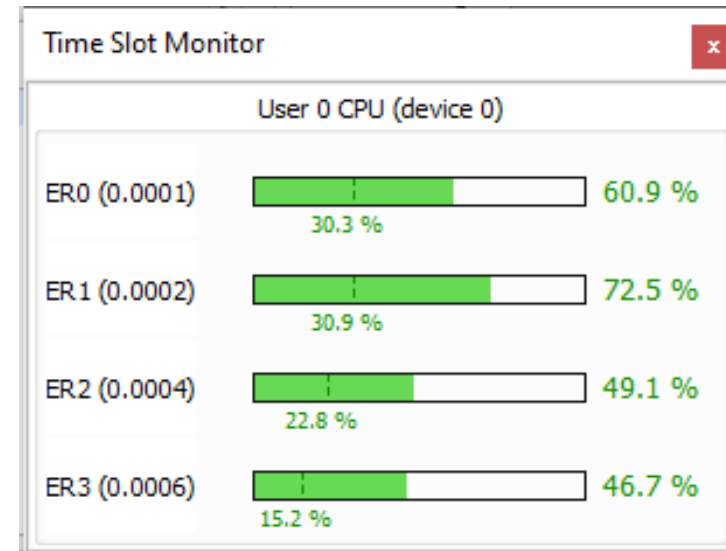

Additional Features

Sinusoidal sources API function enhancement

- ❑ New argument added to the `set_source_sine_waveform()` HIL API function: `apply_at_phase`
- ❑ Triggering transient events (dips, swells etc.) now made more convenient

```
hil.set_source_sine_waveform(name="Vs1",  
                             rms := 100,  
                             apply_at_phase := 90)
```

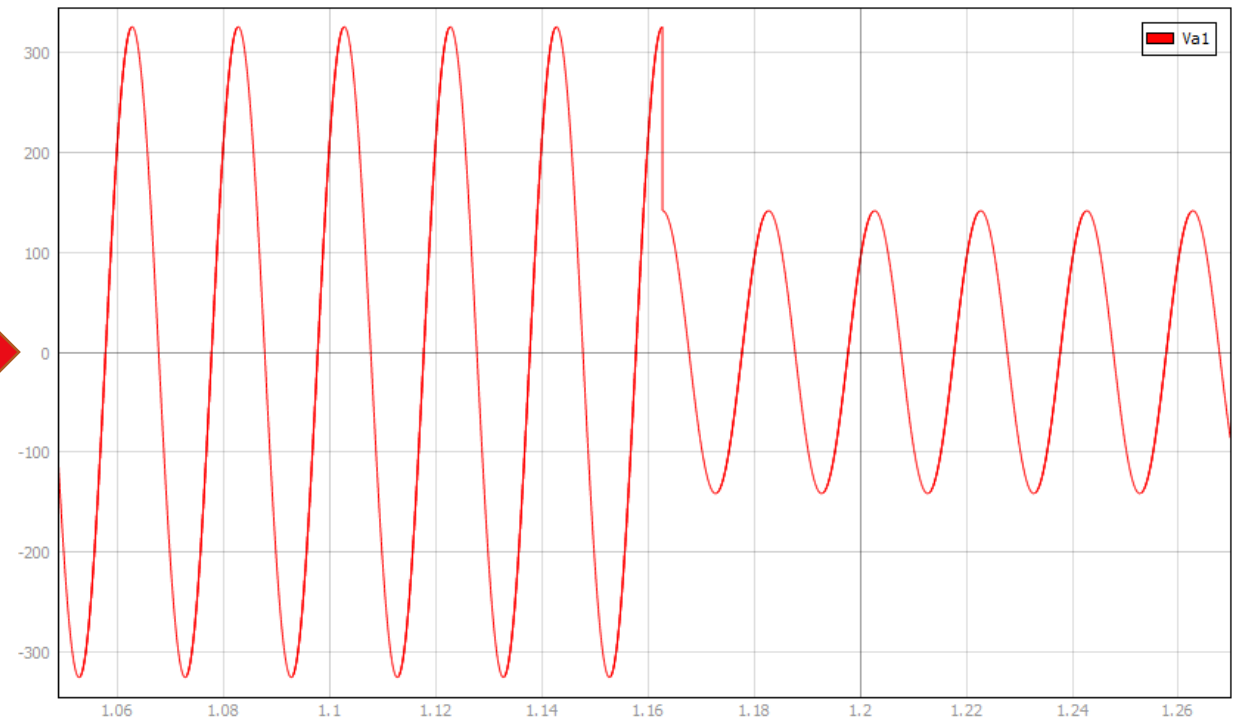

Additional Features

More options for your communication interfaces

- Flexible Ethernet port selection
 - Support for PROFINET added



IO Device



UX improvements

Component Bypassing

- Disable a component, without having to redo the wiring

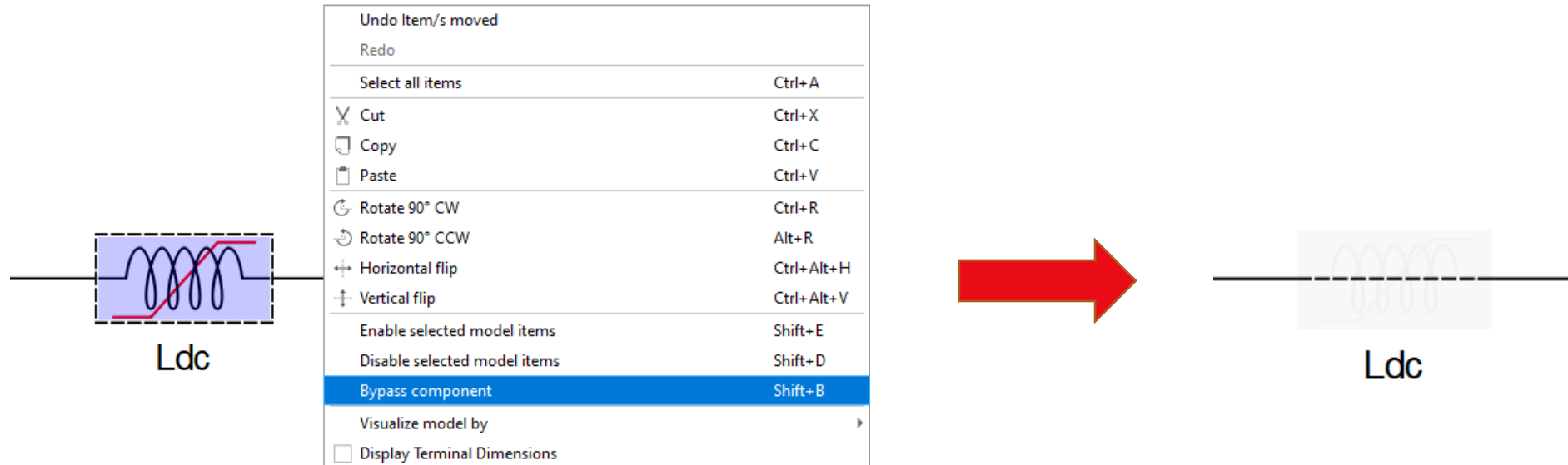

UX improvements

Add schematic area

- Colored and named rectangular area-box to separate circuit sections
- Circuit sections can be easily dragged as a group throughout the model
- Circuit sections within the box can still be edited normally

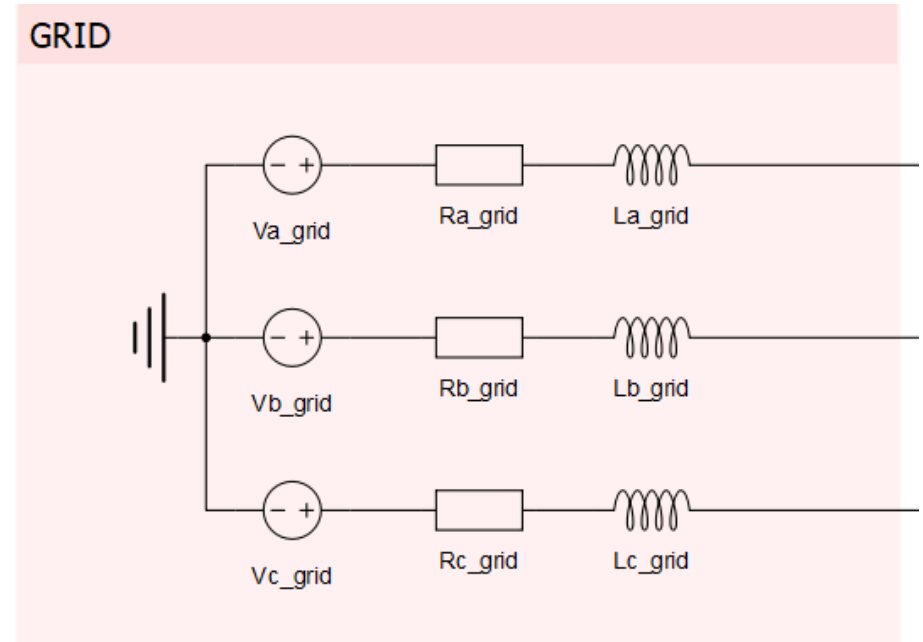



Learn More

- Visit: [Software Release Page](#)
- Contact Us: info@typhoon-hil.com

April 2024

